

Rod Pull and Cabinet Handles

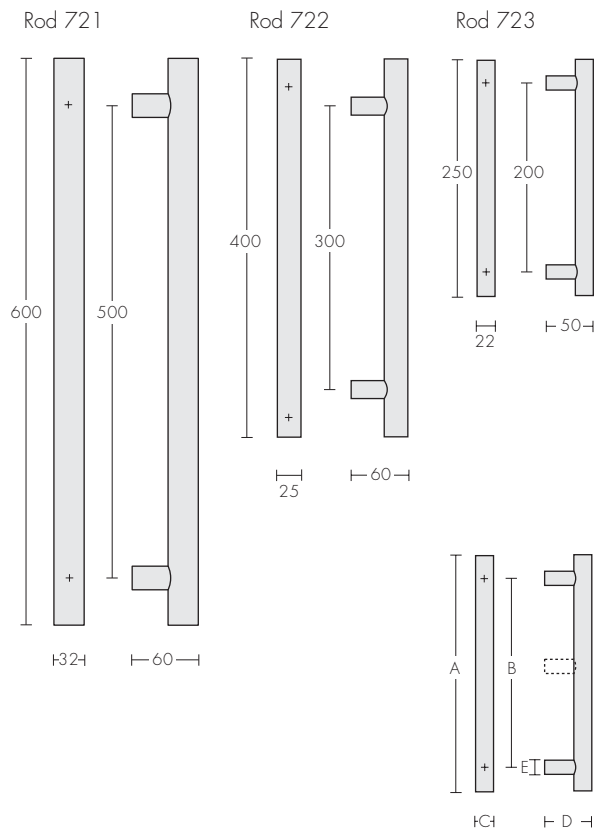

Rod Lever Handle

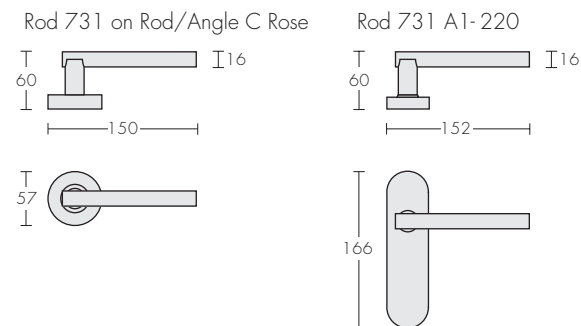

Rod / Angle Escutcheons



Materials

Brass rod is used for electroplated finishes, e.g.: satin chrome plate velvet, polished chrome plate, black chrome plate, etc.

Bronze rod is used for bronze and "Living Finishes" (refer page 119).

The rods are machined with the recess for the pillars to fasten into.

The Rod Pull and Cabinet Handles can also be made from 316 grade stainless steel, for polished or brushed stainless steel finishes. Specify either finish option. The handles are generally made from solid rod for up to 1000mm in length, and diameters up to 32mm.

Tubular handles in 316 grade stainless can be produced for larger sizes. These use an internal nut to fasten the pillars to. Weight and length details need to be considered for shipping, and the practicality of plated finishes for larger handles.

Consult chant™ with your requirements.

Custom Sizes

When custom handles are required, specify:

A = Length

B = Hole centres of pillars

C = Diameter of rod

D = Height of handle

E = Pillar diameter

Standard pillars are 15mm and 19mm diameter (parallel), and 25mm diameter tapered pillars.

Other variations can be made to order.

F = Number of pillars

A central third pillar may be required on extra long handles to avoid the handle flexing.

G = Material/Finish

refer chant™ Product Finishes 4 – 5	refer chant™ Escutcheons 68 – 69	refer Casement Fasteners 88 – 89	refer chant™ Technical 104 – 113
---	--	--	--

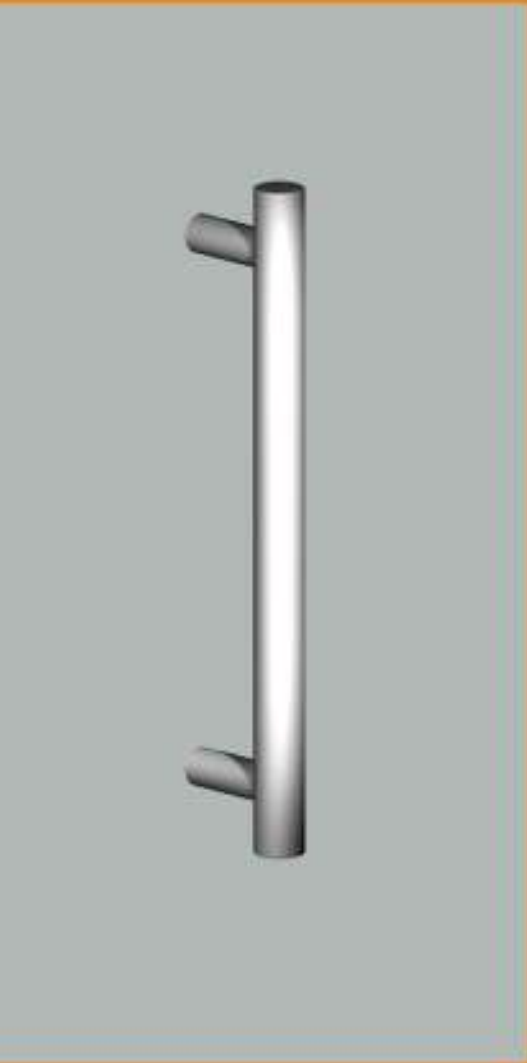

Rod 723



Rod 721



Rod 731 on Rose