

Door Controls

NOVAS



Contents

- Introduction
- 1500 Series Door Closers
- 1300 Series Door Closers
- 1000 Series Door Closers
- 3000 Series Door Closers
- 8000 Series Transom Closers
- 8500 Series Floor Springs



Introduction

NOVAS

Novas Hydraulic doorclosers are designed to suit various residential and commercial applications. By definition, door closers are used to close hinged leaf doors after they have been manually opened. The smooth closing operation is controlled by the adjustable hydraulic rack and pinion mechanism.

In choosing a closer style for a particular application consideration should be given to the type of door being controlled, frame condition, aesthetic and the control features required by the end user.

The size and weight of the door is the main consideration in selecting a closer of the correct strength. Recommended door widths for each closer assume normal operating conditions. If a door is of exceptional height, weight, special construction, or if air pressure differentials exist, a more powerful closer should be considered.

A door closer effectively increases the loading on door hinges and their rate of wear. It is recommended that any door fitted with a door closer should use three or more Novas Ball Bearing/Sintered Bearing Hinges.

It is essential that the door be clear in the doorframe and when fitted with a lock the latch bolt must engage freely with the strike.

Floor or wall mounted doorstops should be fitted to prevent possible damage to the door frame and fitted hardware.



Contact Details

Nova Hardware Pty Ltd
Unit 11/899 Wellington Road,
Rowville, Victoria 3178.
Phone: 03 9755 6590
Fax: 03 9755 7603
Email: sales@nova-hardware.com.au
Web: www.nova-hardware.com.au

Guarantee

Nova Hardware Pty Ltd guarantee all their products against defects in workmanship and materials subject to inspection and confirmation of fair wear and tear.

Nova Hardware Pty Ltd assumes no liability for:

1. Improper installation or failure to follow fitting instructions.
2. Product failure due to improper maintenance or unfair wear and tear.
3. Indirect or consequential loss or damage.
4. Cost of removal and/or replacement.
5. Cost of freight and/or travelling expenses.
6. Some plated finishes are classified as soft finishes. Deterioration is possible under some climatic conditions and cannot be unconditionally guaranteed.

Consult your local Nova Representative or Agent for advice on all finishes.



1500 Series Door Closers

1500 Series Door Closers

1500 Series door closers are a power adjustable surface mounted hydraulic door closer. Applications include regular arm, parallel arm, top jamb, track arm, delayed action and adjustable backcheck function.



Door Closer Selection Chart

Size	Regular Arm/Top Jamb			Parallel Arm/Track Arm			Door Weight Kg.
	Interior Door	Exterior Door		Interior Door	Exterior Door		
		Swing In	Swing Out		Swing In	Swing Out	
2	900	800	700	800	700	600	25-45
3	1050	900	800	900	800	700	40-60
4	1200	1050	900	1050	900	800	55-75
5	1350	1200	1050	1200	1050	900	70-90

Maximum door width dimension in mm

Door Closer Applications

Mounting Details

Regular Arm Installation

Closer is fixed to the pull (hinge) side of the door.

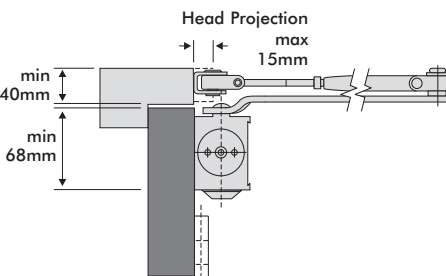

Parallel Arm Installation

Closer is fixed to the push (opposite to hinge) side of the door.

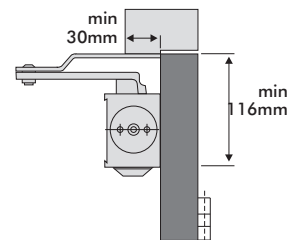

Top Jamb Installation

Closer is fixed to the Top Jamb on the push (opposite to hinge) side of the door.

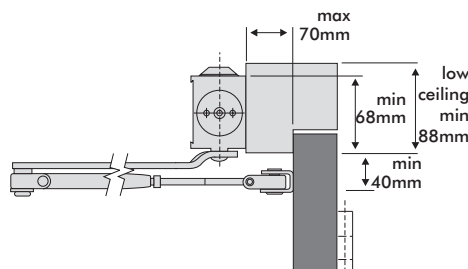

Regular Track Arm Installation

Closer is fixed to the pull (hinge) side of the door.

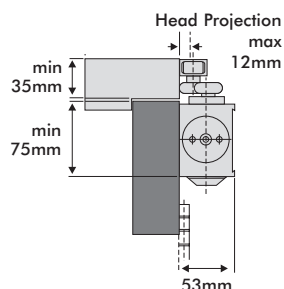

Top Jamb Track Arm Installation

Closer is fixed to the Top Jamb on the pull (hinge) side of the door.

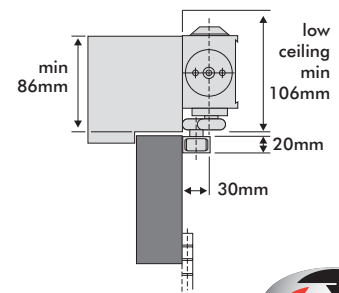

1500 Series Door Closers

Technical Data – Limiting Dimensions

Regular Arm

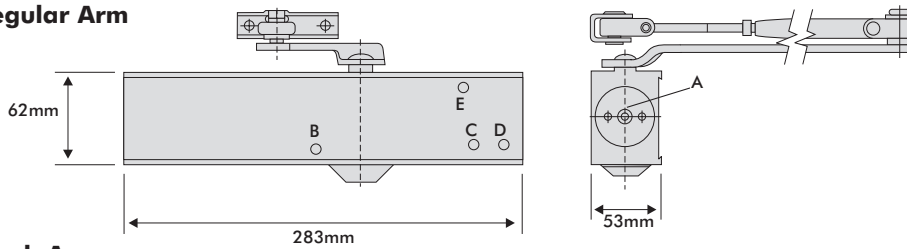

Track Arm

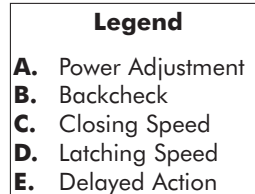
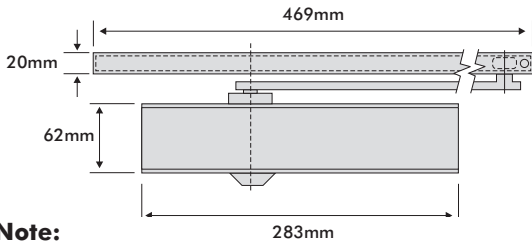

Note:

Specification of track arm and parallel arm applications should consider the single strength reduction in power.

A. Power Adjustment

Simple adjustment by rotation of a captive screw adjusts the size of the closer to the desired strength. 1500BC (size 2 - 5), 1500DA and 1500TR (size 1 - 4).

B. Backcheck

Adjustable backcheck provides cushioning effect on opening to give protection to the door and fittings.

C. Closing Speed

Captive valve is conveniently located on the face of the door closer to control the closing speed.

D. Latching Speed

A separate adjustment valve to accelerate or decelerate the door to ensure positive latching.

E. Delayed Action

Delays the closing action of the door to allow slow moving traffic to pass.

Adjustment Details

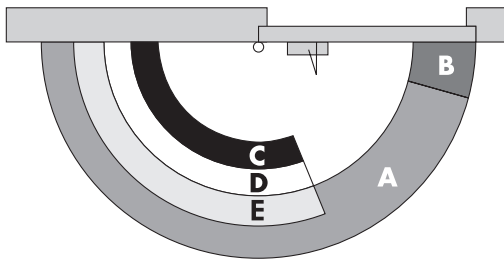

A	Closing Range	15° - 180°
B	Latching Range	0° - 15°
C	Backcheck Range	70° - 180°
D	Hold Open Range	70° - 180°
E	Delayed Action	70° - 180°

Mechanism & Case

High Pressure diecast aluminium body, rack and pinion hydraulic controlled piston door closer. Reversible for left-hand and right-hand doors.

Ordering Procedure

Cat. No.	Description	Finish
1500BC	Door Closer Adj (2-5)	SIL/SSS/PSS
1500DA	Door Closer Adj (1-4)	SIL/SSS/PSS
1500TR	Track Arm Door Closer (1-4)	SIL/SSS/PSS

Accessories to suit 1500 Series Closer

1500 - 10	Hold Arm Open to suit	SIL
1500 - 11	Track Arm Assembly	SIL
1500 - 20	Drop Plate to suit	SIL
1500 - 30	Parallel Arm Bracket	SIL
1500 - 40	Cover	SSS/PSS

Finish

SIL	Silver
SSS	Satin Stainless Steel
PSS	Polished Stainless Steel

Fire Rating



FIRE DOORS

Approved on fire door assemblies up to 2 hours in accordance with Australian Standard AS 1905 - Part 1 - Fire resistant door sets.



1300V Series Door Closers

1300 Series Door Closer

The Novas 1300V Series Hydraulic Door Closer comes with a slimline body, compact in size and with power adjustment for maximum flexibility. Applications include regular arm, parallel arm, top jamb, track arm and adjustable backcheck function.



Door Closer Selection Chart

Size	Regular Arm/Top Jamb			Parallel Arm/Track Arm			Door Weight Kgs
	Interior Door	Exterior Door		Interior Door	Exterior Door		
		Swing Out	Swing In		Swing Out	Swing In	
2	900	800	700	800	700	600	25-45
3	1050	900	800	900	800	700	40-60
4	1200	1050	900	1050	900	800	55-75

Maximum door width dimension in mm

Door Closer Applications

Mounting Details

Regular Arm Installation

Closer is fixed to the pull (hinge) side of the door.

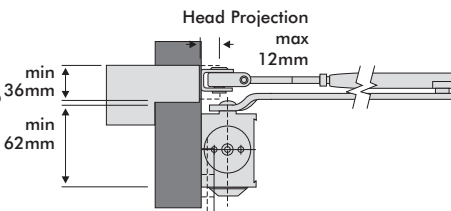

Parallel Arm Installation

Closer is fixed to the push (opposite to hinge) side of the door.

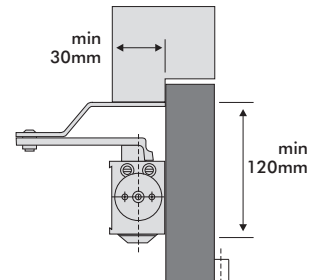

Top Jamb Installation

Closer is fixed to the Top Jamb on the push (opposite to hinge) side of the door.

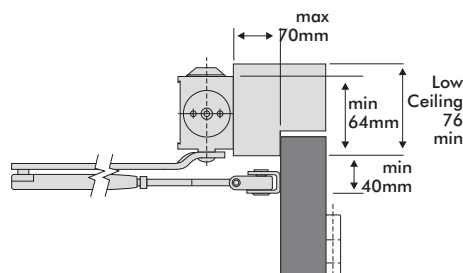

Regular Track Arm Installation

Closer is fixed to the pull (hinge) side of the door.

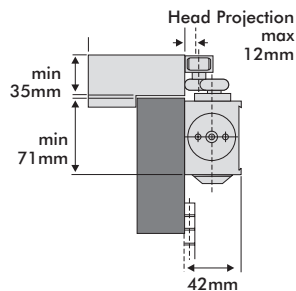

Top Jamb Track Arm Installation

Closer is fixed to the Top Jamb on the pull (hinge) side of the door.

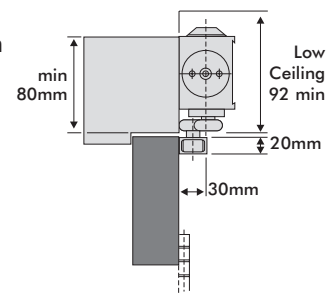

1300V Series Door Closers

Technical Data – Limiting Dimensions

Regular Arm

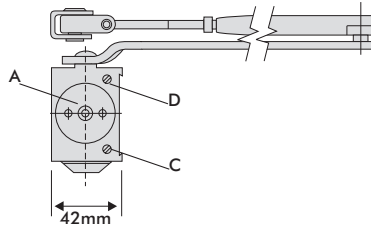
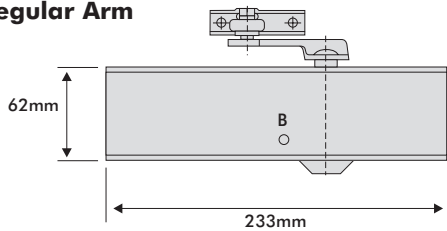

Track Arm

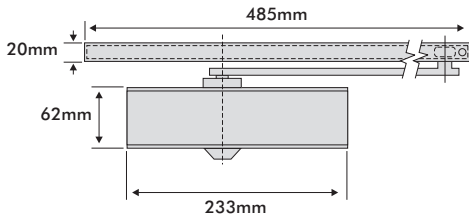

Legend	
A.	Power Adjustment
B.	Backcheck
C.	Closing Speed
D.	Latching Speed

Note:

- Specification of track arm and parallel arm applications should consider the single strength reduction in power.
- The 1300V Door Closer is **not** available with delayed action function.

A. Power Adjustment

Simple adjustment by rotation of a captive screw adjusts the size of the closer to the desired strength. 1300VBC (size 2 - 4), 1300VTR (size 1 - 3).

B. Backcheck

Adjustable backcheck provides cushioning effect on opening to give protection to the door and fittings.

C. Closing Speed

Captive valve is conveniently located on the end of the door closer to control the closing speed.

D. Latching Speed

A separate adjustment valve to accelerate or decelerate the door to ensure positive latching.

Adjustment Details

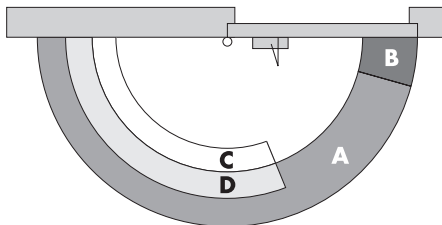

A	Closing Range	15° - 180°
B	Latching Range	0° - 15°
C	Backcheck Range	70° - 180°
D	Hold Open range	70° - 180°

Mechanism & Case

High Pressure diecast aluminium body, rack and pinion hydraulic controlled piston door closer. Reversible for left-hand and right-hand doors.

Ordering Procedure

Cat No.	Description	Finish
1300VBC	Doorcloser Adj (2-4)	SIL/SSS/PSS
1300VTR	Track Arm Door Closer (1-3)	SIL/SSS/PSS

Accessories to suit 1300V Series Closer

1300 - 10	Hold Arm Open to suit	SIL
1300 - 11	Track Arm Assembly	SIL
1300 - 20	Drop Plate to suit	SIL
1300 - 30	Parallel Arm Bracket	SIL
1300 - 40	Cover	SSS/PSS

Finish

SIL	Silver
SSS	Satin Stainless Steel
PSS	Polished Stainless Steel

Fire Rating



FIRE DOORS

Approved on fire door assemblies up to 2 hours in accordance with Australian Standard AS 1905 - Part 1 - Fire resistant door sets.



1000 Series Door Closers

1000 Series Door Closer

The 1000 series doorcloser is a fixed strength hydraulic door closer. Applications include regular arm, parallel arm, top jamb, track arm and adjustable backcheck function.



Door Closer Selection Chart

Size No.	Regular Arm/Top Jamb			Parallel Arm/Track Arm			Door Weight Kg.
	Interior Door	Exterior Door		Interior Door	Exterior Door		
		Swing Out	Swing In		Swing Out	Swing In	
3	1050	900	800	900	800	700	40-60

Maximum door width dimension in mm

Door Closer Applications

Mounting Details

Regular Arm Installation

Closer is fixed to the pull (hinge) side of the door

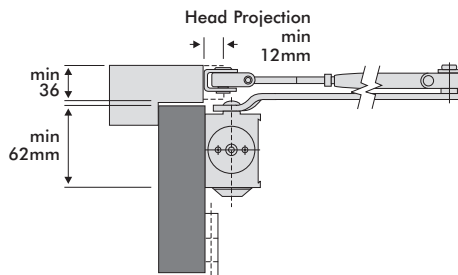

Parallel Arm Installation

Closer is fixed to the push (opposite to hinge) side of the door.

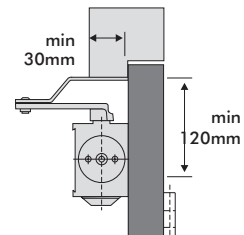

Top Jamb Installation

Closer is fixed to the Top Jamb on the push (opposite to hinge) side of the door.

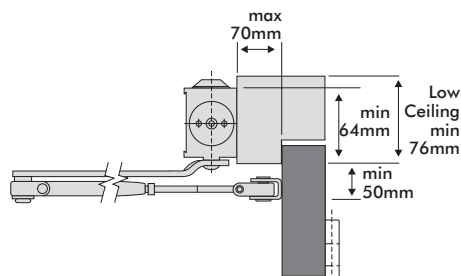

Regular Track Arm Installation

Closer is fixed to the pull (hinge) side of the door.

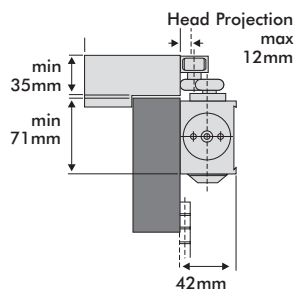

Track Arm Installation

Closer is fixed to the Top Jamb on the pull (hinge) side of the door.

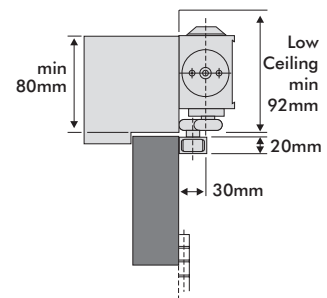

1000 Series Door Closers

Technical Data – Limiting Dimensions

Regular Arm

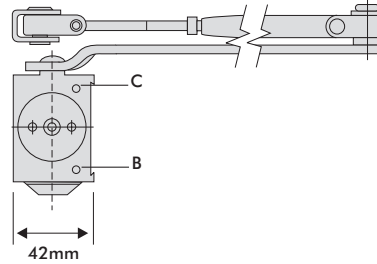
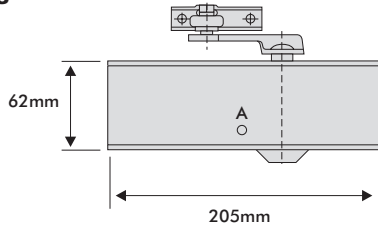

Track Arm

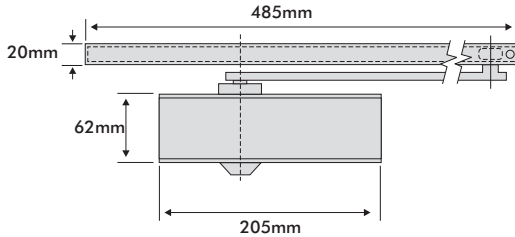

Legend	
A.	Backcheck
B.	Closing Speed
C.	Latching Speed

Note:

Specification of track arm and parallel arm applications should consider the single strength reduction in power.

A. Backcheck

Adjustable backcheck provides cushioning effect on opening to give protection to the door and fittings.

B. Closing Speed

Captive valve is conveniently located on the end of the door closer to control the closing speed.

C. Latching Speed

A separate adjustment valve to accelerate or decelerate the door to ensure positive latching.

Adjustment Details

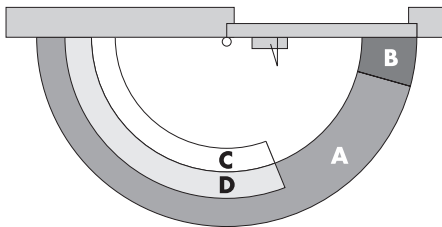

A	Closing Range	15° - 180°
B	Latching Range	0° - 15°
C	Backcheck Range	70° - 180°
D	Hold Open Range	70° - 180°

Ordering Procedure

Cat. No.	Description Fixed Strength	Finish
1003ABC	Size 3 closer	SIL/SSS/PSS
1003ABCTR	Size 3 Track Arm Closer	SIL/SSS/PSS

Accessories to suit 1000 Series Closer

1000 - 10	Hold Operation Arm	SIL
1000 - 11	Track Arm Assembly	SIL
1000 - 20	Drop Plate	SIL
1000 - 30	Parallel Arm Bracket	SIL
1000 - 40	Cover	SSS/PSS

Finish

SIL	Silver
SSS	Satin Stainless Steel
PSS	Polished Stainless Steel

Mechanism & Case

High Pressure diecast aluminium body, rack and pinion hydraulic controlled piston door closer. Reversible for left-hand and right-hand doors.

Fire Rating



FIRE DOORS

Approved on fire door assemblies up to 2 hours in accordance with Australian Standard AS 1905 - Part 1 - Fire resistant door sets.



3000 Series Door Closers

3000 Series Door Closers

The Novas 3000 series door closers have been designed for usage where economy and ease of installation are the absolute requirements. The closers are smaller in size and have efficient mechanisms giving a powerful performance.

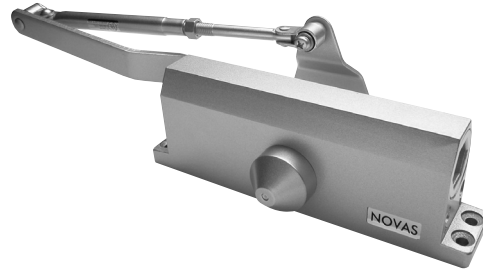

Door Closer Selection Chart

Cat. No.	Regular Arm		Parallel Arm		Door Weight Kg.
	Interior Door	Exterior Door	Interior Door	Exterior Door	
3003	1050	900	900	800	40-65

Maximum door width dimension in mm

Door Closer Applications

Mounting Details – 3000 Series

Regular Arm Installation

Closer is fixed to the pull (hinge) side of the door.

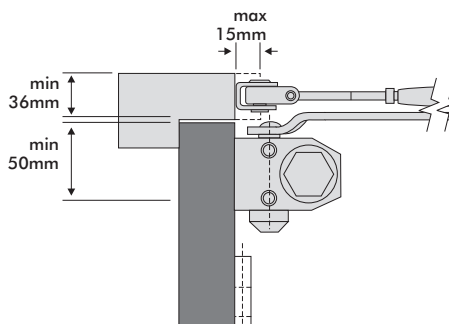

Parallel Arm Installation

Closer is fixed to the push (opposite to hinge) side of the door. Parallel arm application, using a cranked arm assembly overcomes the requirement for a drop plate in most cases. (refer above dimensions)

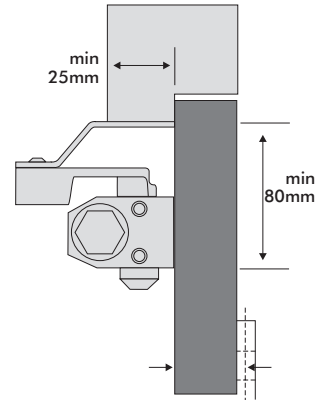

Top Jamb Installation

Closer is fixed to the Top Jamb on pull (hinge) side of the door.

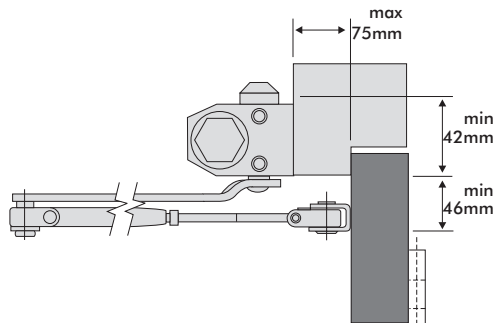

3000 Series Door Closers

Technical Data – Limiting Dimensions

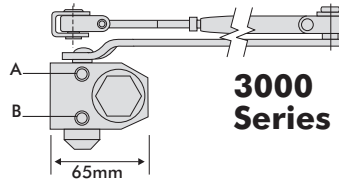
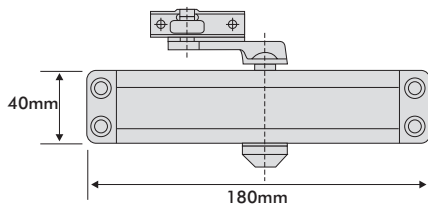

Legend	
A	Closing Speed
B	Latching Speed

A Closing Speed

Captive valve is conveniently located on the end of the door closer to control the closing speed.

B Latching Speed

A separate adjustment valve to accelerate or decelerate the door to ensure positive latching.

Adjustment Details

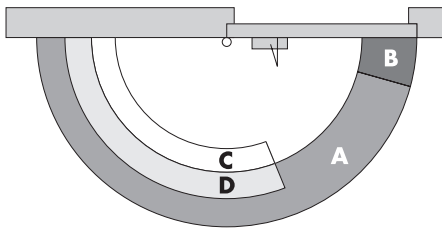

A	Closing Range	15° - 180°
B	Latching Range	0° - 15°
C	Backcheck Range	70° - 180°
D	Hold Open Range	70° - 180°

Mechanism & Case

High Pressure diecast aluminium body, rack and pinion hydraulic controlled piston door closer. Reversible for left-hand and right-hand doors.

Ordering Procedure

Cat. No.	Description	Finish
3003	Universal Size 3 door closer	SIL
3003BC	Size 3 door closer with backcheck	SIL

Accessories to suit 3000 Series Closer

3000 - 10	Hold Open Arm	SIL
3000 - 20	Drop Plate	SIL
3000 - 30	Parallel Arm Bracket	SIL

Finish

SIL	Silver
-----	--------

Fire Rating - 3003BC only



FIRE DOORS

Approved on fire door assemblies up to 2 hours in accordance with Australian Standard AS 1905 - Part 1 - Fire resistant door sets.



8000 Series Transom Closers

The Novas fully concealed transom closers are designed to provide positive centring and door control on manually operated single or double action internal and external Aluminium doors.

The most important factors to be considered when selecting manually operated transom closer spring strength are the door size, the environment in which the door will operate and people using the door.

Selection of Spring Strength

For external doors, the size of the door and effect of wind upon its surface area must be considered in relation to the spring strength required to hold the door closed against wind pressure, and then this must be balanced by the ability of the users to exert sufficient pressure on the door to push it or pull it open. The push plate/pull handle must also be considered, as this may drastically diminish the available leverage.

The following chart is provided as a guide to choosing the best spring strength for your requirements.



Hydraulic Unit Spring Strength			Door	
Size	Spring Strength	Closing Force (In kpm)	Maximum Width mm	Maximum Weight kg.
2	Regular	2.5	1150	80 - 120

Regular Opening

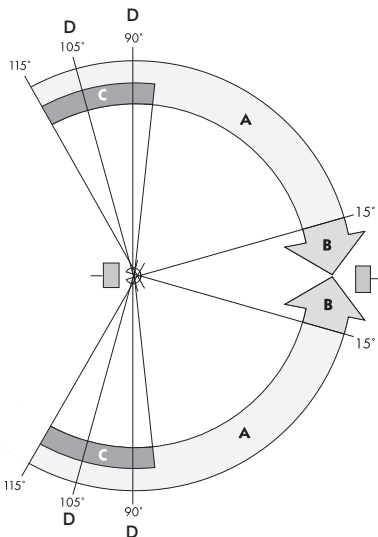

A	Closing Range	15° - 115°
B	Latching Range	0° - 15°
C	Backcheck Range	85° - 115°
D	Hold Open	90° or 115°

Technical Data – Limiting Dimensions

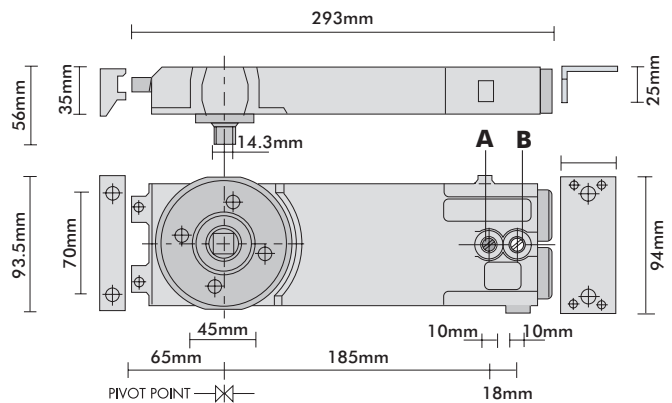

Legend

- A.** Closing Speed
- B.** Latching Speed

A. Closing Speed

Captive valve is conveniently located on the underneath side of the body to control the closing speed.

B. Latching Speed

A separate adjustment valve to accelerate or decelerate the door to ensure positive centring.



8000 Series Transom Closers

Technical Data

- Standard Arm 'T' option Product Code 8000-1010
- Offering lateral adjustment through hinge style
- Fully adjustable, vertically within opening & central parking positions
- Hole and centre lines in channel for easy location of pivot point
- Hexagon spanner provided
Universal Bottom Pivot
Product Code 800-0021
- Fully adjustable height 31.5mm to 58.5mm
- 100kg loading radial bearing
- 70mm Standard Pivot Point
- 65mm Pivot Point, Glass Door, cut on 5mm 'V' groove line
- Threshold & Tie Bar secured threaded back plate
- 1 full turn equals 2mm adjustment

Side Load Arm

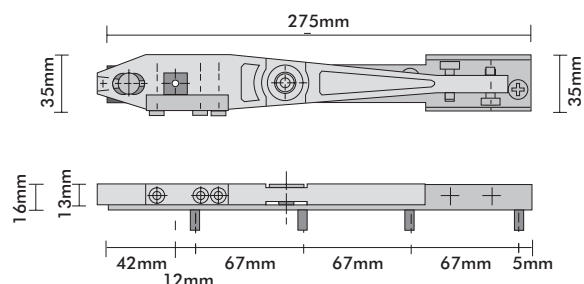

Bottom Pivot

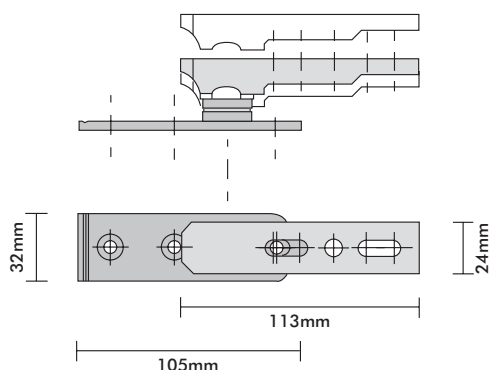

Backcheck

Built-in cushion backcheck from 85° prevents damage to doors in adverse conditions or where a door swing is limited to 90°. It is recommended that a doorstop be installed to provide a positive backdrop to prevent damage to door furniture and furnished wall surfaces. It is recommended that a door stop be installed to provide a positive backstop to prevent damage to door furniture and finished wall surfaces.

Ordering Procedure

Cat. No.	Description
8002 NHO	Strength 2, Non Hold Open
8002 90HO	Strength 2, 90° Hold Open
8002 105HO	Strength 2, 105° Hold Open



8000 ADJ Series Transom Closers

3 in 1 Transom Closer

3 units will give you the function, strength and flexibility previously required by 9 separate fixed strength closers.

The 8000 ADJ has a spring power adjustment which allows you to pre-adjust your closer to the desired strength to suit your application. No more issues in those difficult door applications with outside winds or inside air conditioning affecting your decision which size transom closer to use.

For convenience, the Novas 8000 ADJ is factory set to size 1. By turning the spring power adjustment screw clockwise, sizes 2 & 3 can be easily set.

The Novas fully concealed 8000 ADJ transom closer is designed to provide positive centring and door control on manually operated single or double action internal and external Aluminium doors.

With the 8000 ADJ you have the maximum flexibility to adjust the strength of closer function on site.



Simple adjustment for spring strengths from 1 to 3.



Features

- 500,000 cycle tested
- Stock reduction, cost savings and better stock turnovers.
- Maximum flexibility on site
- Option NHO, HO 90° and HO 105°

8000 ADJ Transom Closer Specifications

Hydraulic Unit Spring Strength			Door	
Size	Spring Strength	Closing Force (In kpm)	Maximum Width mm	Maximum Weight kg.
1	Light	1.73	950	60 - 80
2	Regular	2.34	1150	80 - 120
3	Heavy	3.16	1250	100 - 150



8000 ADJ Series Transom Closers

Technical Data

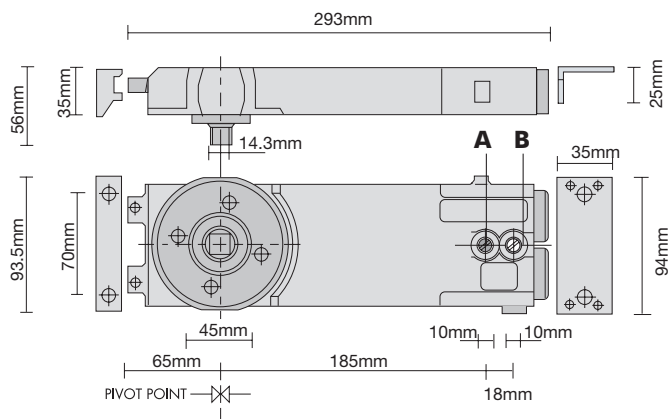

Side Load Arm

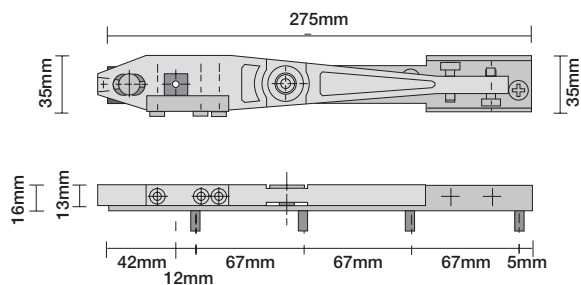

Bottom Pivot

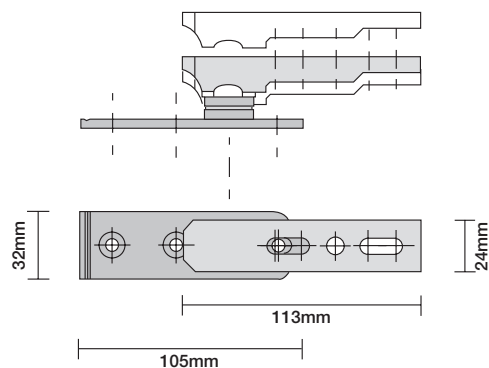

Ordering Procedure

Cat. No.	Description
8000ADJ-NHO	Novas Adjustable Transom Closer Size 1 - 3 Non Hold Open 6
8000ADJ-90 HO	Novas Adjustable Transom Closer Size 1 - 3 90 Deg Hold Open 6
8000ADJ-105 HO	Novas Adjustable Transom Closer Size 1 - 3 105 Deg Hold Open 6

